

Quick Exhaust Valve

Hydraulic

1/2" FEMALE NPT, 10,000 PSI

Model 13QS44



Conforms to the SEP category of the European Pressure Equipment Directive
Issue No. 97/23/EC

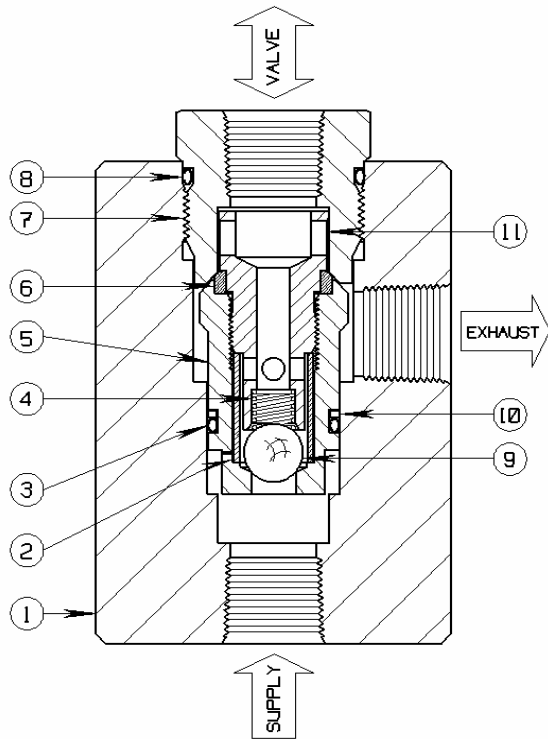

The **13QS44** is a two position, Poppet operated control valve assembly for **10,000 PSI** hydraulic service. This **high flow exhaust** valve establishes flow from the Supply to Valve connections (inlet to outlet) to open a Surface Safety Valve (SSV or hydraulic Actuator) automatically with each application of operating pressure. A loss or significant decrease of operating hydraulic pressure will rapidly unseat the Poppet to establish high volume reverse or Exhaust flow. Rapid closure of an Actuator valve is assured with the use of a Quick Exhaust Valve.

The 13SQ44 Quick Exhaust Valve utilizes a small internal orifice that bypasses the Poppet assembly to provide thermal expansion capability. It also minimizes the effects of pump cycling or small volume fluid leaks, to maintain proper operating volume or pressure.

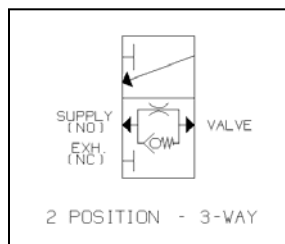

PARTS LIST:

- | | |
|-----------------------|--------------------|
| 1. Valve Body | 7. Retainer |
| 2. Restriction Sleeve | 8. O Ring * |
| 3. O Ring * | 9. Ball * |
| 4. Spring * | 10. Back Up Ring * |
| 5. Valve Poppet | 11. Seal Guide |
| 6. Kel-F Seat * | |

* Indicates parts included in a Repair Kit

Sigma Model Number 13QS44

1/2" FEMALE NPT, 10,000 PSI

Product Specifications

Flow Control Application: Normally Open

Control Function: Three-Way – Poppet Assembly Operated

Flow Capacity: High Flow Service

Pressure Rating Body (Control Ports): 10,000 PSI maximum (690 bar)

Seal Material: Viton and Kel-F

Connection Size (Body): 1/2-14 Female N.P.T. (Supply, Valve, Exhaust)

Wetted Component Material (Metal): 410 Body, 316 Stainless Steel and 17-4PH SS

Mounting: Field Mount (Standard)

Orifice: .718 Diameter **Cv Factor:** 4.33

Weight: 8 Lbs.

Operating Temperature: -20° F to +250° F (-29° C to +121° C)

Overall Dimensions: 4-5/8 Height x 3 Diameter (11.75 cm Height x 7.62 cm Diameter)

Pressure Equipment Directive (PED): This product conforms to the SEP Category of the European P.E.D.

Installation and Maintenance Instructions:

Install between the interface valve and the actuator. This is done by threading the pipe or fitting from the control system into the port labeled "Supply". The piping from the actuator is threaded into the port labeled "Valve". The piping from the hydraulic fluid reservoir is threaded into the port labeled "Exhaust". A significant loss in pressure within the control system will trigger an exhaust of the actuator through the valve port and out the exhaust port. Sigma recommends the use of appropriate thread sealant for each port connection.

Shelf Position Port Status

Supply Inlet	Instrument supply pressure open to cylinder (Actuator)
Valve	Outlet Pressure to cylinder (Closed to Exhaust Port)
Exhaust	Depressurizes cylinder upon loss of Supply Inlet