

Hydraulic Regulators

Non-Relieving Regulators

1/4" FEMALE NPT, 3500 - 6000 PSI MAX OUTPUT, 10,000 PSI MAX INLET

Model 28RG20



Conforms to the SEP category of the European Pressure Equipment Directive
Issue No. 97/23/EC

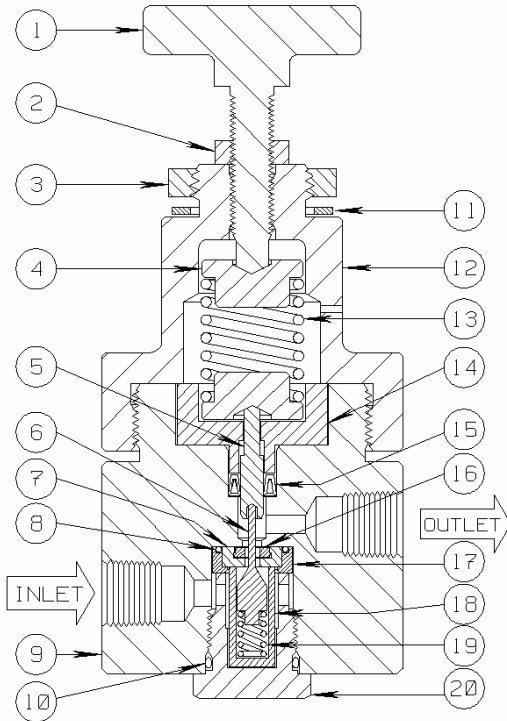

The **28RG20** is a two position, pressure reducing (spring/sensing piston modulating combination), flow control valve. Pressure Regulators are typically used to reduce source or instrument supply pressure from up to 10,000 PSI to a specific lower operating pressure (3,500-6,000 PSI). The reduced operating pressure provided from the Regulator outlet connection will be maintained within a predetermined operating pressure range or limit, required by the receiving control circuit or a control device.

Turning the Adjustment Knob clockwise will increase the Spring exerted tension to increase the Regulator output pressure. Rotating the Adjustment Knob counterclockwise will decrease the Regulator output pressure. Once the exact operating output pressure is achieved, the Lock Nut (2) should be tightened against the Spring Housing to maintain the appropriate output pressure setting.

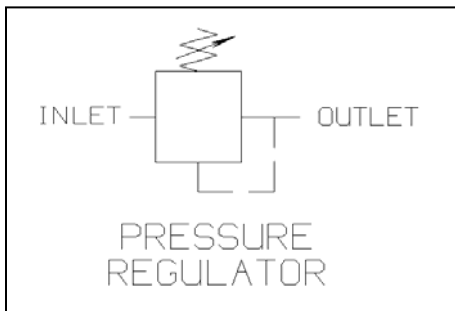

PARTS LIST:

- | | |
|--------------------|------------------------|
| 1. Adjustment Knob | 11. Panel Seal Ring |
| 2. Hex Lock Nut | 12. Spring Housing |
| 3. Panel Nut | 13. Spring * |
| 4. Spring Guide | 14. Packing Retainer |
| 5. Sensing Piston | 15. U-Cup Packing * |
| 6. Valve Pin * | 16. Seat Back Up * |
| 7. Kel-F Seat * | 17. Seat Guide * |
| 8. O Ring * | 18. SS Porous Filter * |
| 9. Valve Body | 19. Spring * |
| 10. O Ring * | 20. Retainer |

* Indicates parts included in a Repair Kit

Sigma Model Number 28RG20
1/4" FEMALE NPT, 3500 - 6000 PSI MAX OUTPUT, 10,000 PSI MAX INLET

Product Specifications

Control Function: Pressure Reducing Flow Control (High Pressure In - Low Pressure Out)

Flow Control Application: Normally Open

Body Pressure Rating: 10,000 PSI maximum (690 bar) inlet pressure

Adjustment Range Capability (Regulated Pressure): 3,500 – 6,000 PSI maximum outlet

Manual Pressure Adjusting Operator: Knob (360° Rotating Screw)

Media Service: Hydraulic, Pneumatic, Natural Gas, Nitrogen

Connection Size (Body): 1/4-18 Female N.P.T. Inlet and Outlet

Orifice: 7/64 Diameter **Cv Factor:** .11

Component Material (Metal): 316 Stainless Steel and 17-4PH SS

Seal Material: Viton

Panel Mount: Yes

Panel Hole Cutout Size Required: 1 Diameter

Weight: 4 Lbs.

Operating Temperature: -20° F to +250° F (-29° C to +121° C)

Overall Dimensions: 5-1/4 Height x 2-1/2 Diameter (13.34 cm Height x 6.35 cm Diameter)

Pressure Equipment Directive (PED): This product conforms to the SEP Category of the European P.E.D.

Installation and Maintenance Instructions:

Remove the Hex Lock Nut (#2), Adjustment Knob (#1), and Panel Nut (#3). Insert the Pressure Regulator in a pre-drilled 1" diameter hole. Replace the Panel Nut, Adjustment Knob, and Hex Lock Nut. Sigma recommends the use of appropriate thread sealant for each port connection.

Shelf Position Port Status

Inlet Supply High Pressure Fluid Inlet Open to Outlet

Outlet Reduced Pressure Output (to receiving control circuit)

Repair Kit Information

Repair Kits contain all of the Seals and other components typically replaced when repairing the assembly. In order to maintain optimum operating control function.